

211SAC Concrete

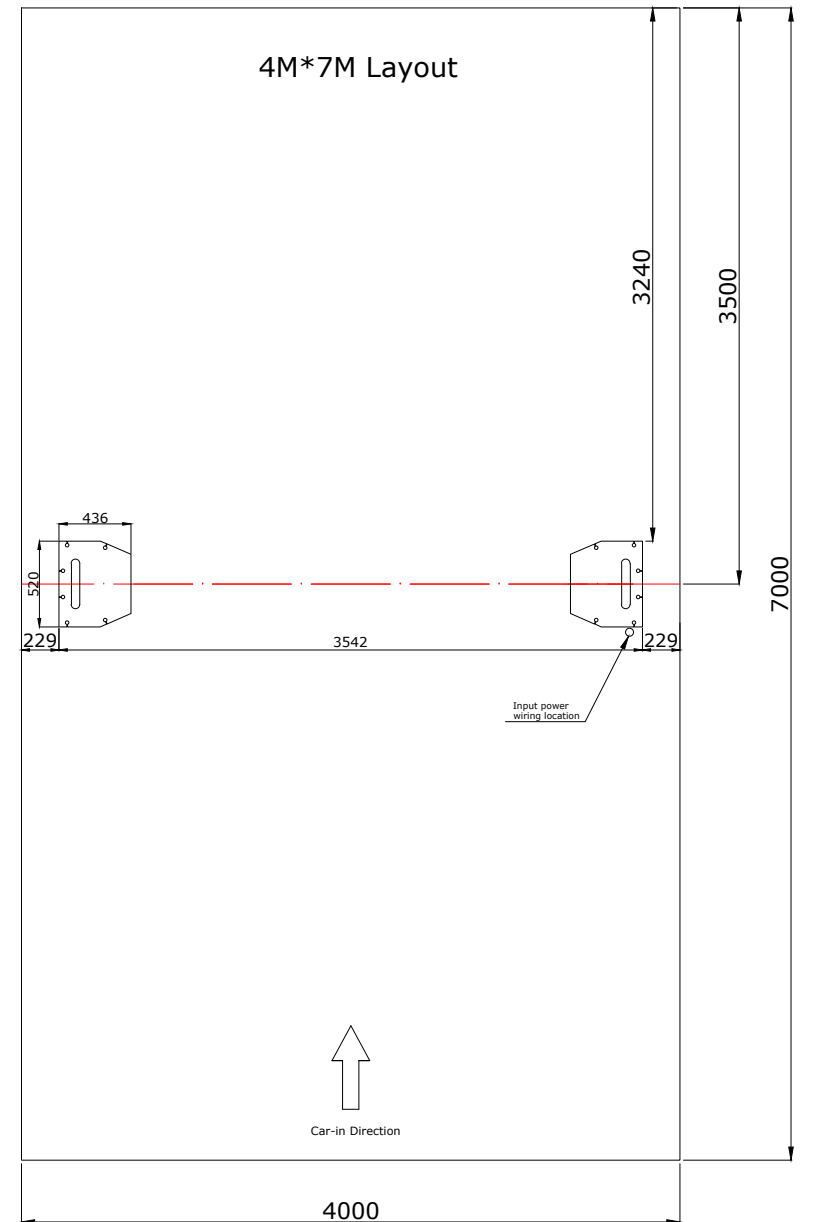
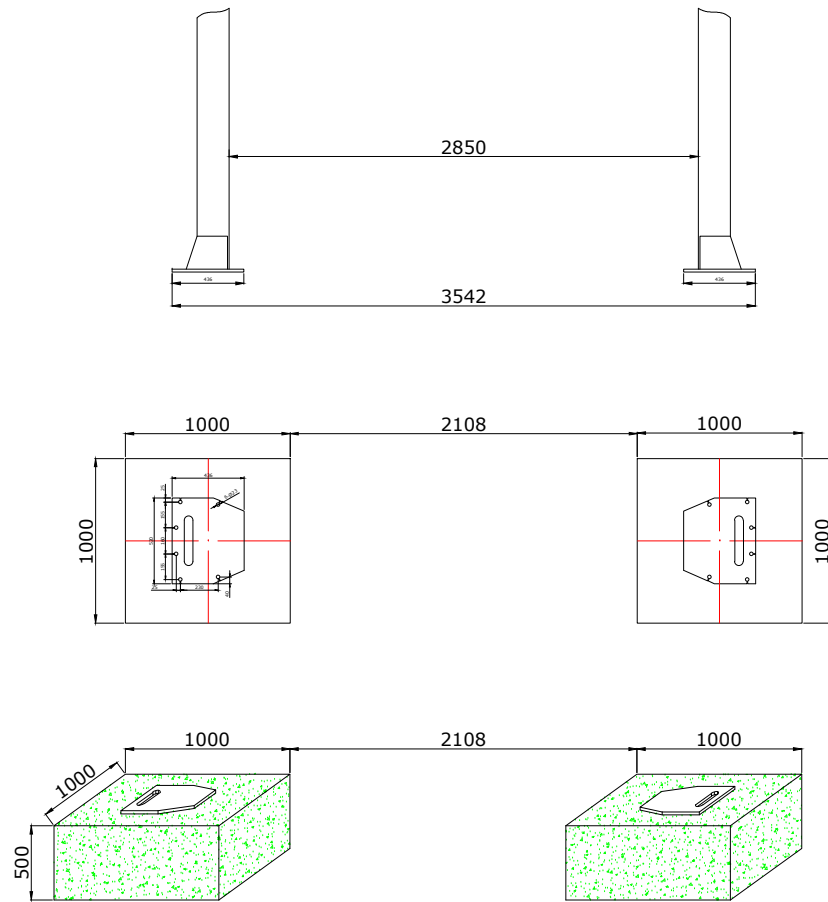

NOTE:

1. When the foundation strength of the installation site is insufficient or the thickness of the cement layer is less than 120mm, two square concrete foundations of 1000*1000*500mm shall be made according to the drawing;
2. For one-time pouring of concrete, the strength of the concrete must be greater than 250kg/cm²/(3500PSI), and there must be no steel bars in the position where the expansion screws are installed;
3. The concrete must be completely dry before installation;